



**Multinational SIG**



**ADI SIG**  
APPLICATIONS DESKTOP INTEGRATOR SIG

2020 FALL EDUCATION SERIES SESSION 2



# THE NITTY GRITTY – TRANSACTIONS, RECONCILIATIONS & AUDIT

Session 2: The “Tough Part” of Integrating the Cloud Service with on Premise Oracle & non-Oracle products and with other Oracle & non-Oracle Cloud products:

**How to control, audit, reconcile!**

10/29/2020 8:30 AM PT, 11:30 AM ET, 16:30 UK, 17:30 CET





SESSION 2 OF 5

# Fall Cloud Series

presented by  
**CREOAL Consulting**  
&  
**Celantra Systems**  
for  
**OATUG**



1. Interfaces & Integrations in The Cloud 10/15/2020  
[Presentation available here](#)
2. **Today 10/29/2020:**  
The Nitty Gritty – Transactions, Interaction, Reconciliations & Audit
3. Financial Reporting in Hybrid and Cloud ERP  
11/12/2020 8:30 PST
4. Analytics or OTBI – What's what and why  
11/19/2020 8:30 PST
5. Implementing Oracle Cloud ERP – What to Know  
12/03/2020 8:30 PST

# RECAP OF FIRST SESSION

UI & Prebuilt | REST & SOAP | FBDI | UCM & OIC | Oracle Cloud

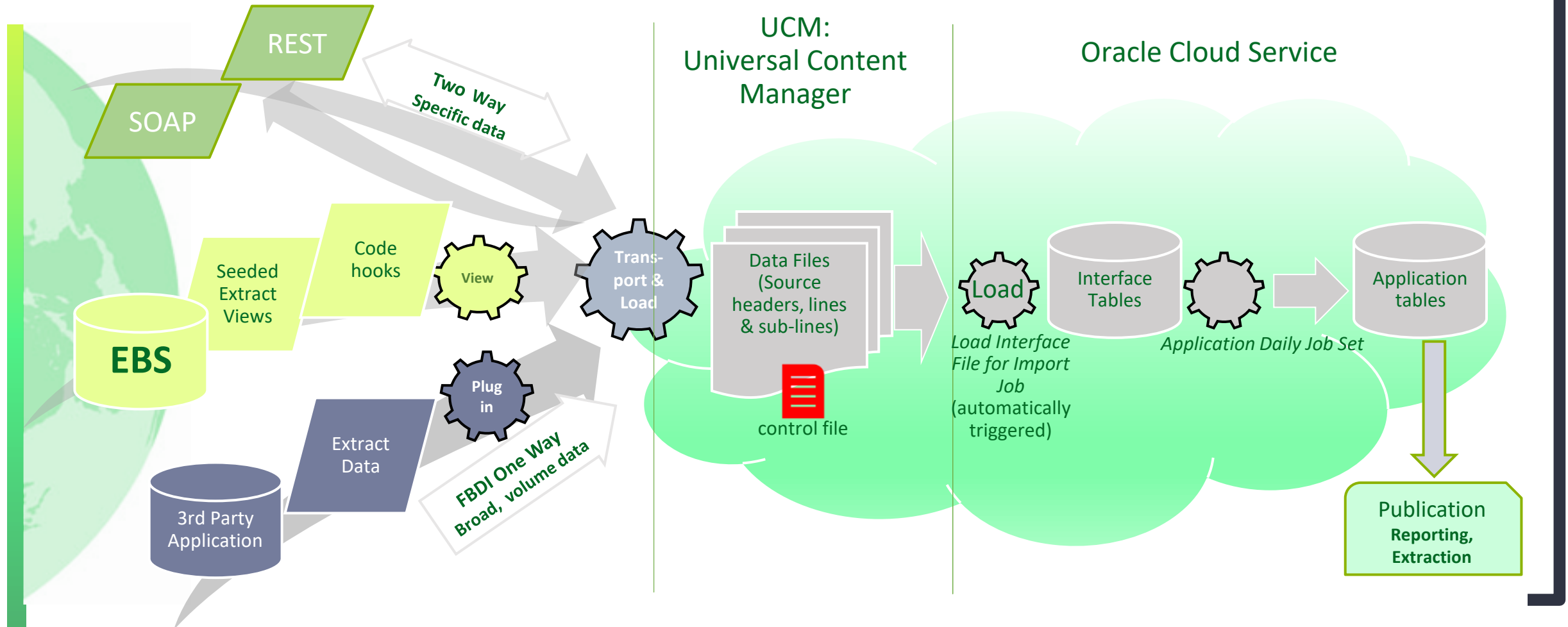



# AGENDA

- Part 1 – Migration and Hybrid Integration (Hans)
  - Concepts & Tools
  - Audit, Reconciliation – The Challenge
- Part 2 – How to Keep Control the Process (Hans & Michael)
  - Approach (Data Model )
  - Processes & Tools
    - “DATASMART” ([PROMATIS])



# CELANTRA SYSTEMS

## THOUGHT LEADERS IN GLOBAL ERP FINANCIALS

- Effective Enterprise Structures & Reporting
- Supply Chain Financials
- Tax Efficient System Implementation
- COA Design & Multi-GAAP Compliance
- Enhanced Localization Solutions
- Cost Effective Global Roll-Out and Support

# CELANTRA SYSTEMS - PROUD TO HELP CUSTOMERS



facebook

Single Operating Unit for a European Union Shared Service Center



TEREX

Global Chart of Accounts & European Implementation



QUALCOMM®

Global Roll Out Strategy & Shared Service Center



**ciena.**  
Experience. Outcomes.

Global Intercompany Supply Chain



STATE STREET

Global Chart of Accounts & Italy Implementation



GE Healthcare

Global Multi-Tier Intercompany Implementation

# One way to understand integration

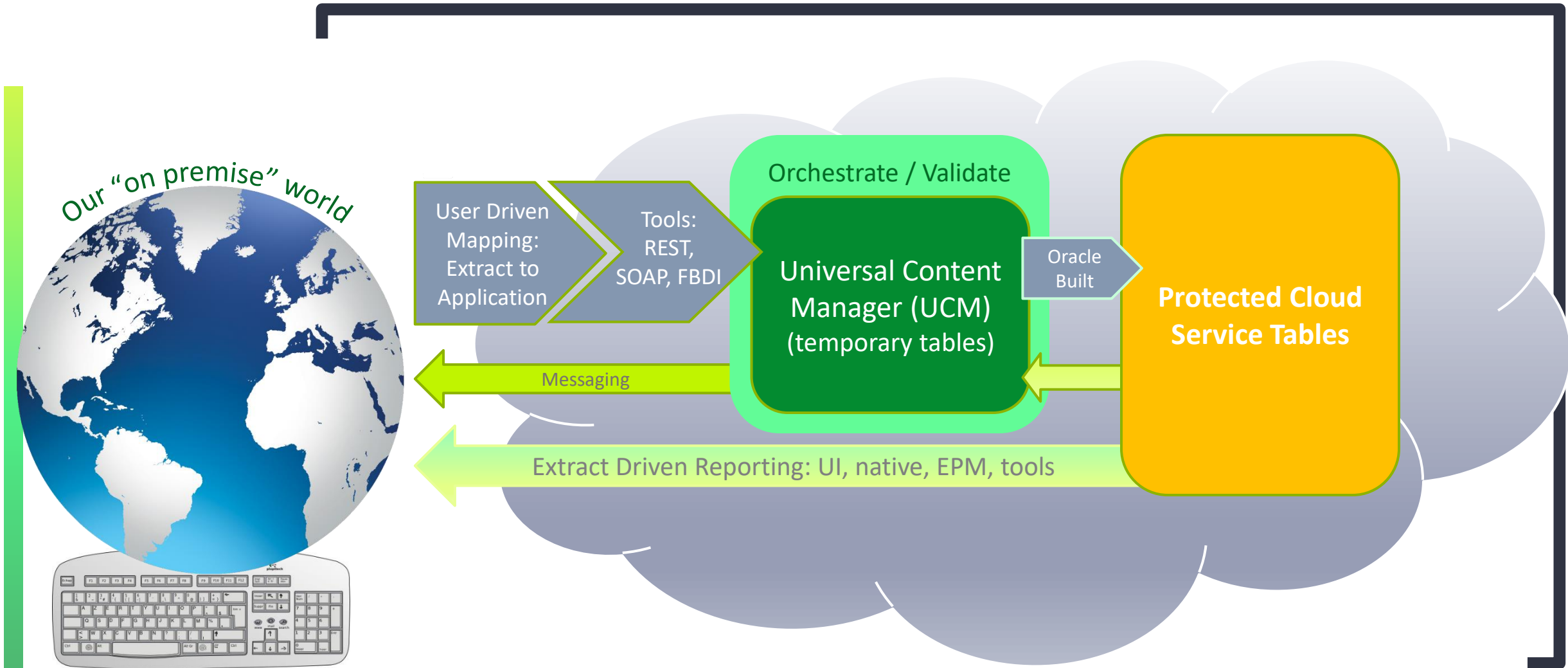



# POLLING QUESTION 1

- Have you experienced or are you concerned about difficulties with the integration / reconciliation between EBS R12 on Premise and Cloud
  - Yes – lots
  - Not at all
  - Very little
  - No live yet, but don't expect big issues
  - No live yet, but very concerned

# THE BUSINESS VIEW

Migration from EBS to Cloud ERP – Moving through Hybrid Model

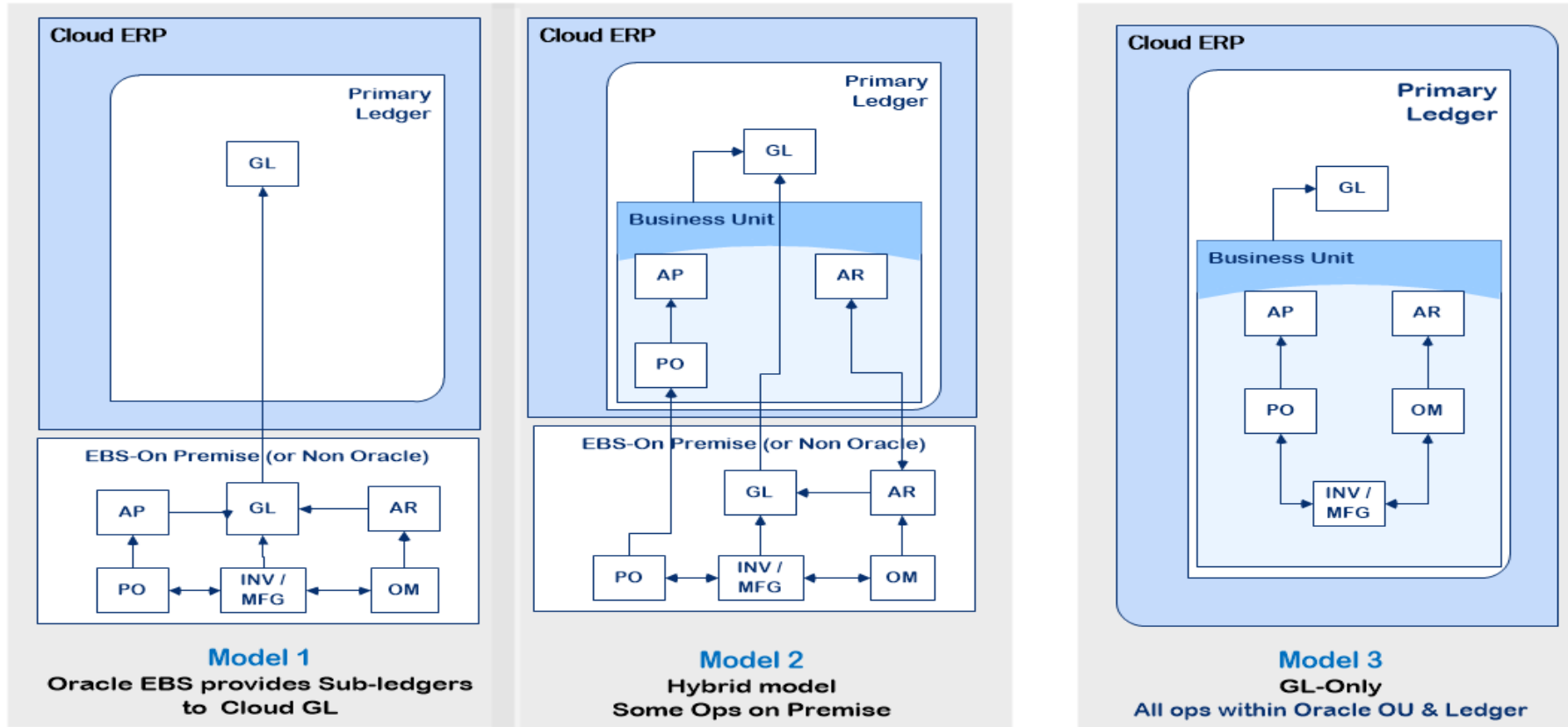



# WHAT ARE THE CHALLENGES ?

## Master Data

Employees

GL Accounts

Items, Costs, vendors,  
customers, locations

- Need Synchronization Across Systems
- Functional Mapping
- New Records
- Incremental & Partial Updates

Duplicates

Missing Data

Errors in Mapping

## Transactions

Journals, Sales Order /  
PO s / Expense Repts

Shipments, Receipts,  
Work Orders

Invoices, Payments,  
Credits

- Need Synchronization Across Systems
- Functional Integration
- New Records
- Incremental & Partial Updates

Opening Balances

Sales Order Changes

Errors in Mapping

# Hybrid Use Case 1 – “Toe in the Water” Model - Corporate on Stays on Premise, Country Sales Organization with Cloud OM and Receivables.

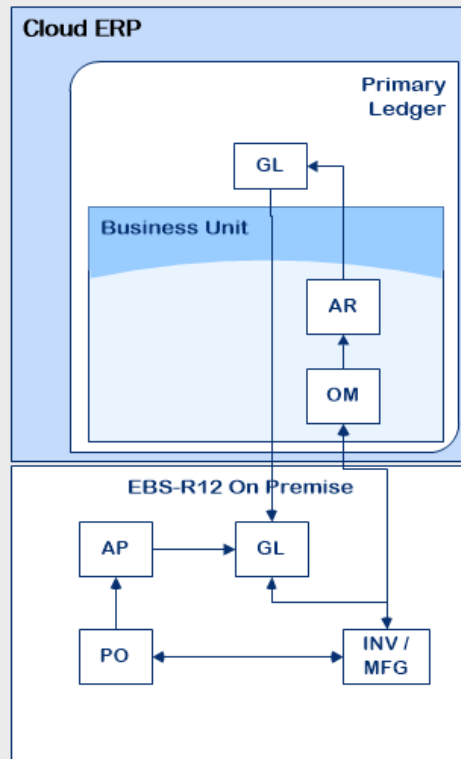

**Model 2**  
Hybrid model  
Some Ops on Premise

- ERP Cloud: Sales Order & Receivable
- EBS: GL, AP, PO, Production, Inventory, Shipping

## Questions:

How do I know when my Cloud Sales Order will be shipped by EBS Inventory system?

Customer has changed my Cloud Sales Order? How do I tell the EBS Shipping?

Master Data Updates: Item in ERP, Customers in the Cloud



# Hybrid Use Case 2 – Global on Cloud ERP Financials, but OM, INV, WIP, Shipping on Premise in R12

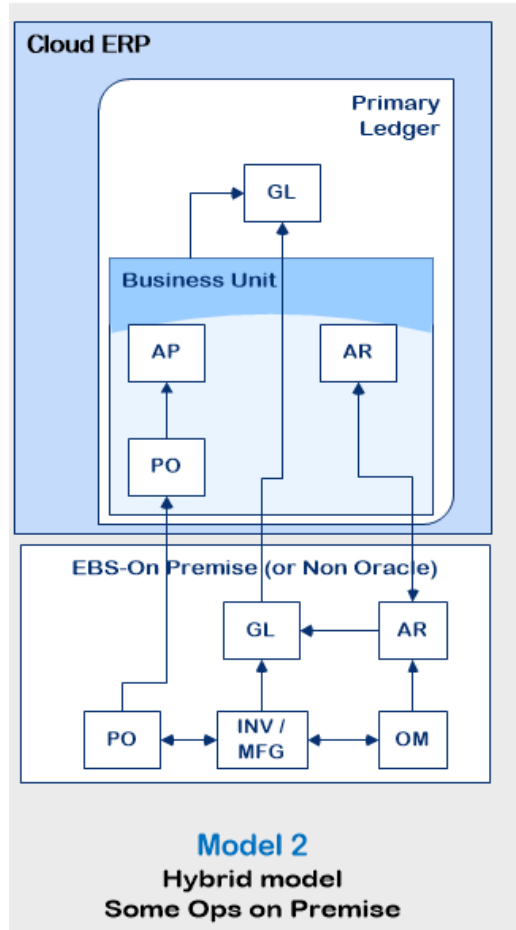

- ERP Cloud: AR, AP, FA, GL
- EBS: Order Management, Production, Inventory, Shipping

## Questions:

Has my EBS Sales Order been invoiced in ERP Cloud ?

Customer is disputing past invoices in Cloud ERP. The credit limit needs to be adjusted in EBS OM

My Customer address and contact has changed in EBS? I need to update the change in Cloud A/R

# POLLING QUESTION 2

How are you planning to resolve any integration / reconciliation issues

- The Oracle Integration Cloud will take care of it, I thought
- I have not really thought of that
- I am looking for ideas and tools to use



# LET'S LOOK AT SOME SOLUTIONS

Time for PROMATIS and Michael Mohl

## POLLING QUESTION 3 – (AFTER 2 USE CASES)

What is your experience with the reconciliation to other “ERP related” systems (EBS instances, Salesforce.com, MFG, production planning), when you need to integrate master and transactional data

- Great – no issues.
- Quite tricky, we need a lot of hand holding / manual processes
- Difficult at first, we built our own reconciliation tools

# PROMATIS GROUP – AT A GLANCE



**140 +**  
Employees



**14 Mio €**  
Total revenues 2020  
Plan 2021: 15 Mio €



**1994**  
Economically successful since  
foundation  
(EBIT positive) and Oracle partner



## 4 countries

GER: Ettlingen, Berlin,  
Hamburg, Muenster  
AT: Vienna  
CH: Zurich  
US: Denver, CO



## Experts

for ERP, SCM, EPM, HCM, CX, PPM, GRC



## Ettlingen

Headquarters  
(Karlsruhe TechnologyRegion)



## 100%

Project success rate since  
formation



## Pioneer

In the process-oriented introduction  
of Oracle applications – SaaS,  
BPM, SOA



## 20+ countries

International project experience



## Owner

-managed company



## Competence

in data analytics, integration, BPM,  
SOA, CM, IoT, AI, ...



## Excellence

Business, digitalization and compre-  
hensive Oracle excellence from one  
source



# PROMATIS DATASMART FOR HYBRID SYSTEMS

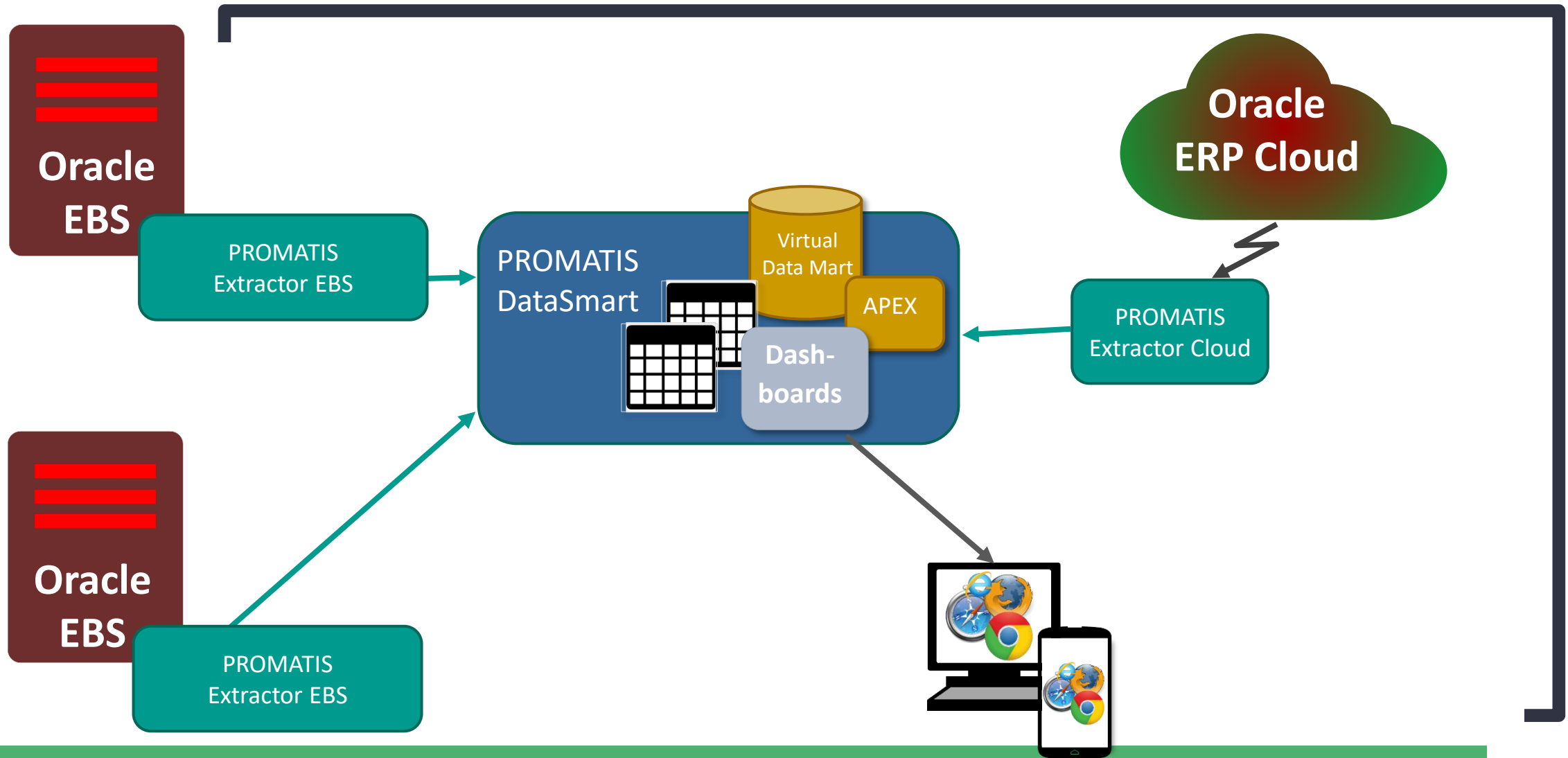

# PROMATIS DATASMART

MEC - JOURNAL - Customers

Q Go Actions Reset

Ledger	Company	Operating Bus...	Ledger Set	Master Value	Customer Num	Customer Name	Name Alterna...	Prospect Num	Partner Type	Payment Term	Partner Status	Tax Num	Vat Num	Site Name
Vision Germany	01	Vision Germany	Vision DE	C-5572-13215	5572	Advantage Corp	-	9926	Organization	N30 - Net 30 D...	Active	-	UK80469875	22001
Vision Germany	01	Vision Germany	Vision DE	C-5572-13211	5572	Advantage Corp	-	9926	Organization	N30 - Net 30 D...	Active	-	DE44056500	21985
Vision Germany	01	Vision Germany	Vision DE	C-5572-13206	5572	Advantage Corp	-	9926	Organization	N30 - Net 30 D...	Active	-	23232466	22062
Vision Germany	01	Vision Germany	Vision DE	C-5511-13098	5511	Specialty Distri...	-	52809	Organization	2% 10, Due 10t...	Active	-	-	23959
Vision Germany	01	Vision Germany	Vision DE	C-5511-13094	5511	Specialty Distri...	-	52809	Organization	2% 10, Due 10t...	Active	-	-	23958
Vision Germany	01	Vision Germany	Vision DE	C-5511-13090	5511	Specialty Distri...	-	52809	Organization	2% 10, Due 10t...	Active	-	-	23957
Vision Germany	01	Vision Germany	Vision DE	C-2268-10333	2268	Vision UK	UK	21824	Organization	30 NET - Net D...	Active	-	-	18410
Vision Germany	01	Vision Germany	Vision DE	C-2206-9641	2206	Vision France	France	12679	Organization	30 NET - Net D...	Active	-	-	17532
Vision Germany	01	Vision Germany	Vision DE	C-2616-8938	2616	ABC Telecomm...	-	23482	Organization	Net 15 - Due in...	Active	-	-	14847
Vision Germany	01	Vision Germany	Vision DE	C-2638-8934	2638	ABC Hardware ...	-	23325	Organization	Net 15 - Due in...	Active	-	-	14766
Vision Germany	01	Vision Germany	Vision DE	C-2575-8930	2575	ABC Corporatio...	ABC World	23355	Organization	Net 15 - Due in...	Active	-	-	14806
Vision Germany	01	Vision Germany	Vision DE	C-2535-8926	2535	ABC Corporatio...	-	23327	Organization	Net 15 - Due in...	Active	-	-	14768
Vision Germany	01	Vision Germany	Vision DE	C-2637-8922	2637	ABC Corporatio...	ABC US	23326	Organization	Net 15 - Due in...	Active	-	-	14767
Vision Germany	01	Vision Germany	Vision DE	C-2164-6603	2164	Vision Netherla...	Netherlands	12474	Organization	30 NET - Net D...	Active	-	-	14972
Vision Germany	01	Vision Germany	Vision DE	C-2960-6968	2960	Floware	-	24476	Organization	30 NET - Net D...	Active	-	DE43251234	15281
Vision Germany	01	Vision Germany	Vision DE	C-1087-5194	1087	Federal Parts	-	1087	Organization	30 NET - Net D...	Active	34-98765	-	4785
Vision Germany	01	Vision Germany	Vision DE	C-1087-5190	1087	Federal Parts	-	1087	Organization	30 NET - Net D...	Active	34-98765	UK54647895	4784
Vision Germany	01	Vision Germany	Vision DE	C-1087-5196	1087	Federal Parts	-	1087	Organization	30 NET - Net D...	Active	34-98765	ED12245678	4783

1 rows selected Total 103

# PROMATIS DATASmart MEC

MEC - JOURNAL - Customers

Q ▾ Go Actions ▾

▼   Customer Name contains world of Business ×

Customer Name	Payment Term	Tax Num	Vat Num	Address Line1	Country	Source Db
World of Business	30 NET - Net Due in 30 Days	65-94238654	-	8475 Elk Grove Road	United States	FUSION
World of Business	30 NET - Net Due in 30 Days	65-94238654	FR5500596	15, rue Rene Coche	France	EBSDB
World of Business	2/10, Net 30 - 2% discount earned if paid wit	65-94238654	E44059874	Ratinger Straße 4	Germany	EBSDB
World of Business	30 NET - Net Due in 30 Days	65-94238654	-	Ratinger Straße 4	Germany	FUSION
World of Business	30 NET - Net Due in 30 Days	65-94238654	-	1000 Unagi st	United States	FUSION
World of Business	2/10, Net 30 - 2% discount earned if paid wit	65-94238654	-	2391 L Street	United States	FUSION



# PROMATIS DATASMART OPEN TRANSACTIONS

Operating Business Unit	Master Value	Transaction Num	Accounted Amount	Assigned Amount	Document Class
▼ Open Amount: -13063,82					
10 Mittelstands-GmbH	C-70001-1245	J201209131779	-1187.62	0	CASH
10 Mittelstands-GmbH	C-70001-1245	J201209131604	-1187.62	0	CASH
10 Mittelstands-GmbH	C-70001-1245	J201208011568	-1187.62	0	CASH
10 Mittelstands-GmbH	C-70001-1245	J201208011556	-1187.62	0	CASH
10 Mittelstands-GmbH	C-70001-1245	J201209131470	-1187.62	0	CASH
10 Mittelstands-GmbH	C-70001-1245	J201209131592	-1187.62	0	CASH
10 Mittelstands-GmbH	C-70001-1245	J201209131580	-1187.62	0	CASH
10 Mittelstands-GmbH	C-UNKNOWN-0	201208011481	-1187.62	0	CASH
10 Mittelstands-GmbH	C-70001-1245	201481	1187.62	2375.24	INV
10 Mittelstands-GmbH	C-70001-1245	J201209131803	-1187.62	0	CASH
10 Mittelstands-GmbH	C-70001-1245	J201209131791	-1187.62	0	CASH
10 Mittelstands-GmbH	C-70001-1245	J201209131716	-1187.62	0	CASH
10 Mittelstands-GmbH	C-70001-1245	J201209131704	-1187.62	0	CASH

# ORACLE CUSTOMER DATA MANAGEMENT MODEL

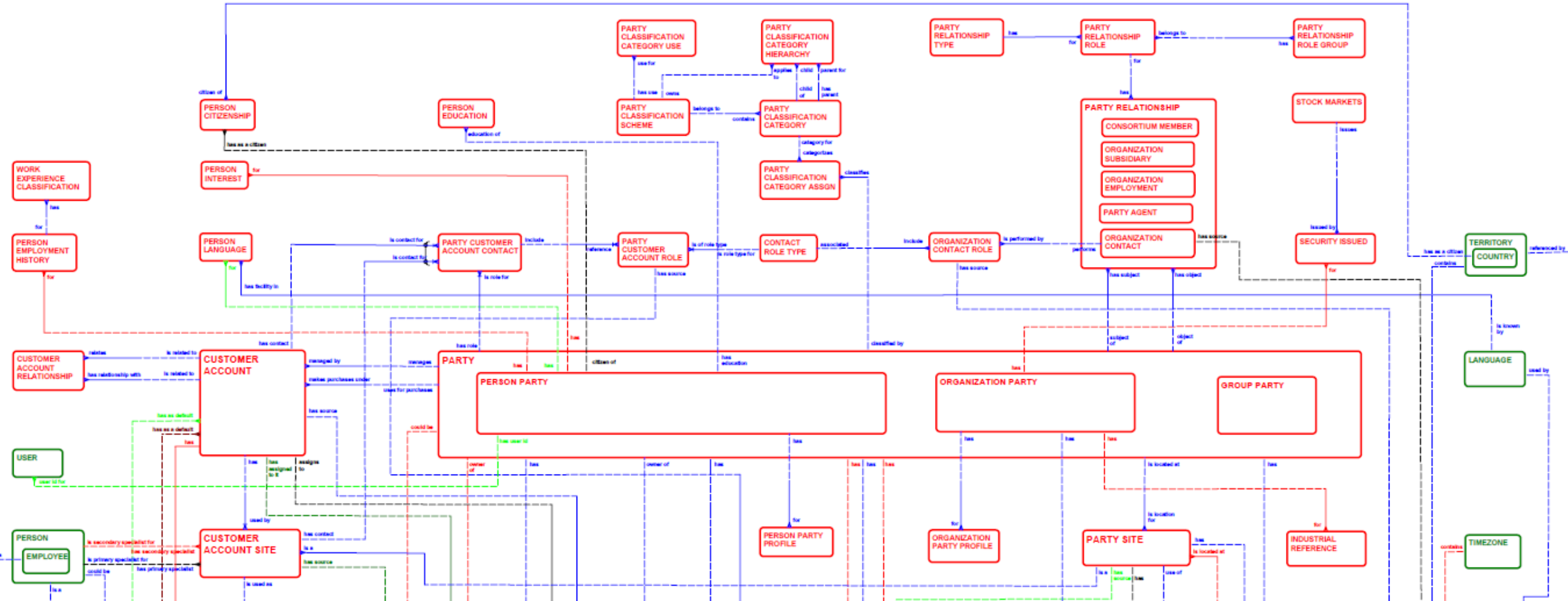

Source: Oracle Customer Data Management – Release 11i.10  
Logical Data Model

# ORACLE ORDER MANAGEMENT MODEL

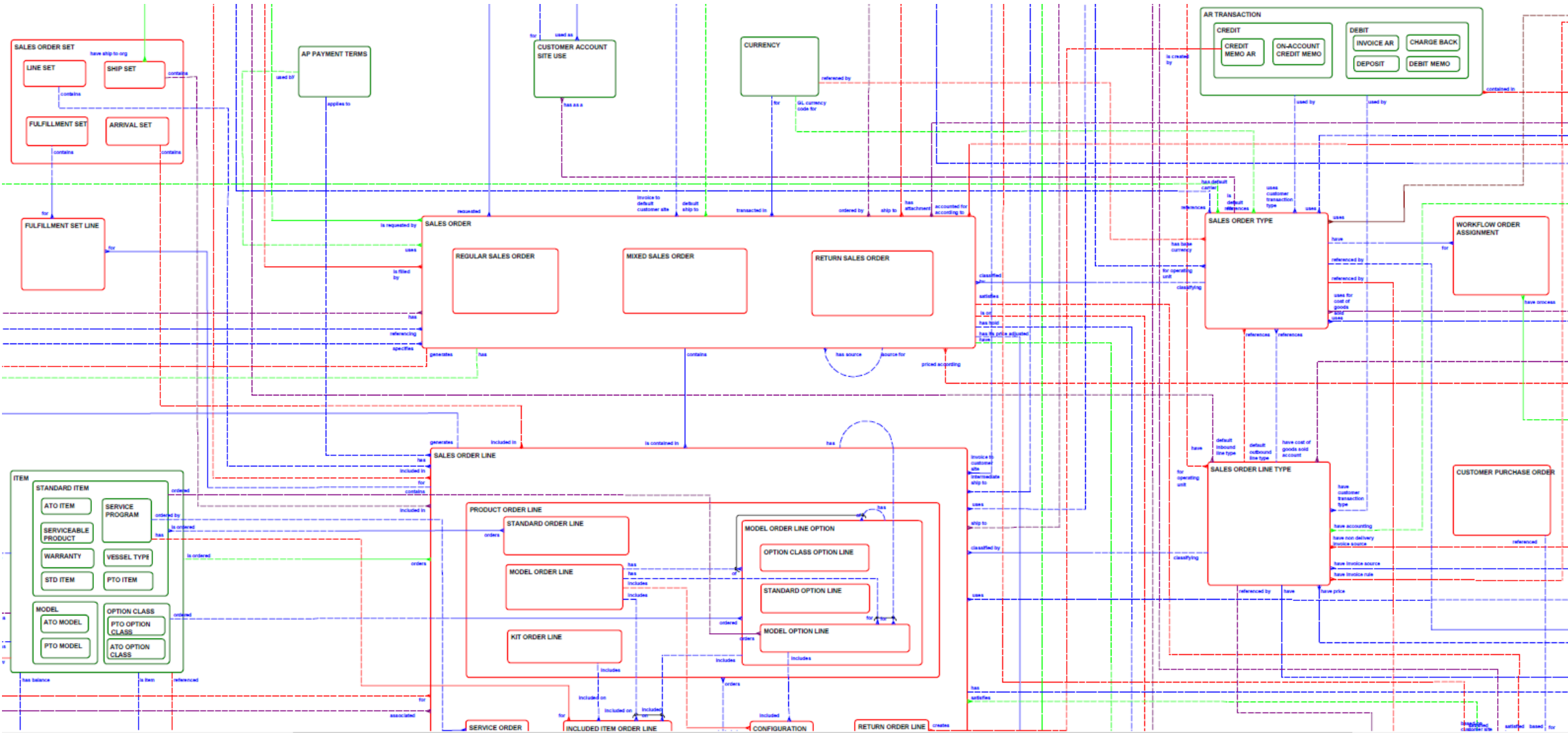

Source: Oracle Order Management - Release 11i  
 Logical Data Model





# SIMPLIFIED PROMATIS DATA MODEL MDM

## Master Data Management (MDM)

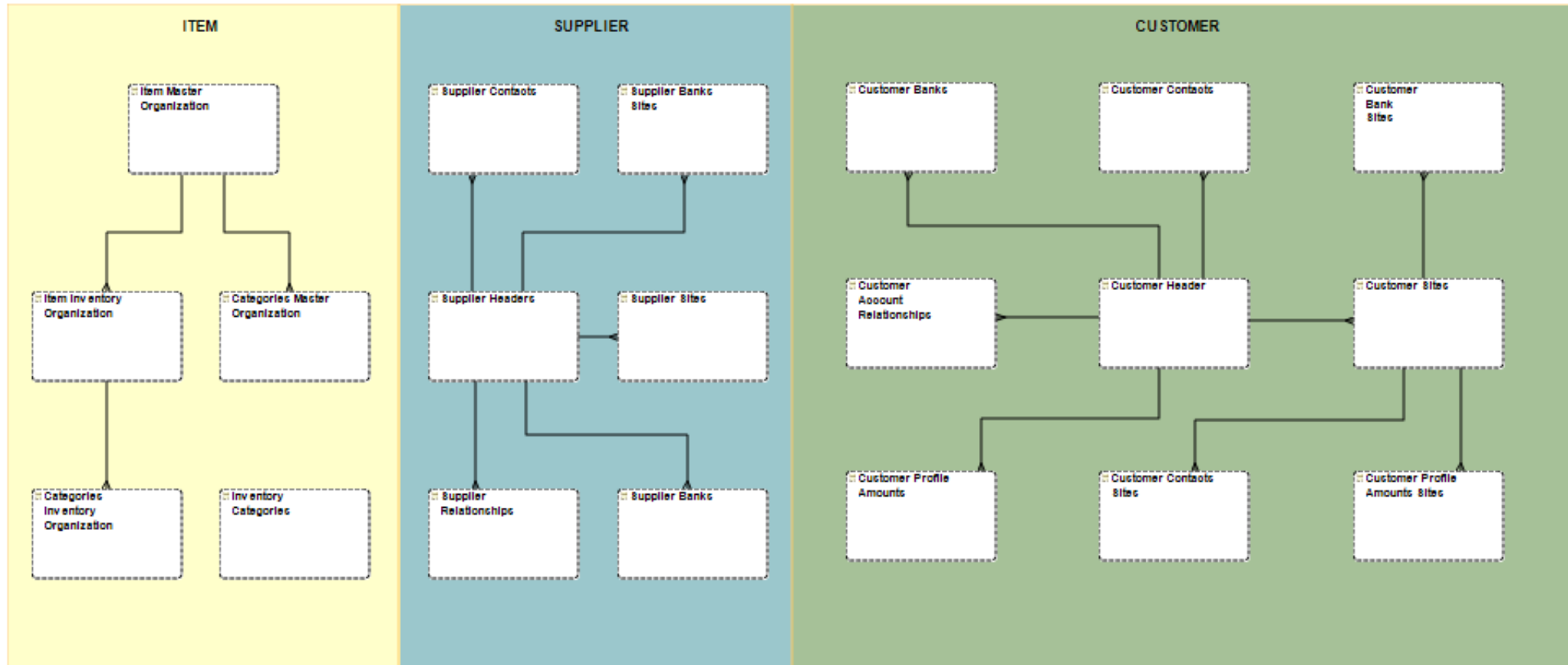

# SIMPLIFIED PROMATIS DATA MODEL 02C

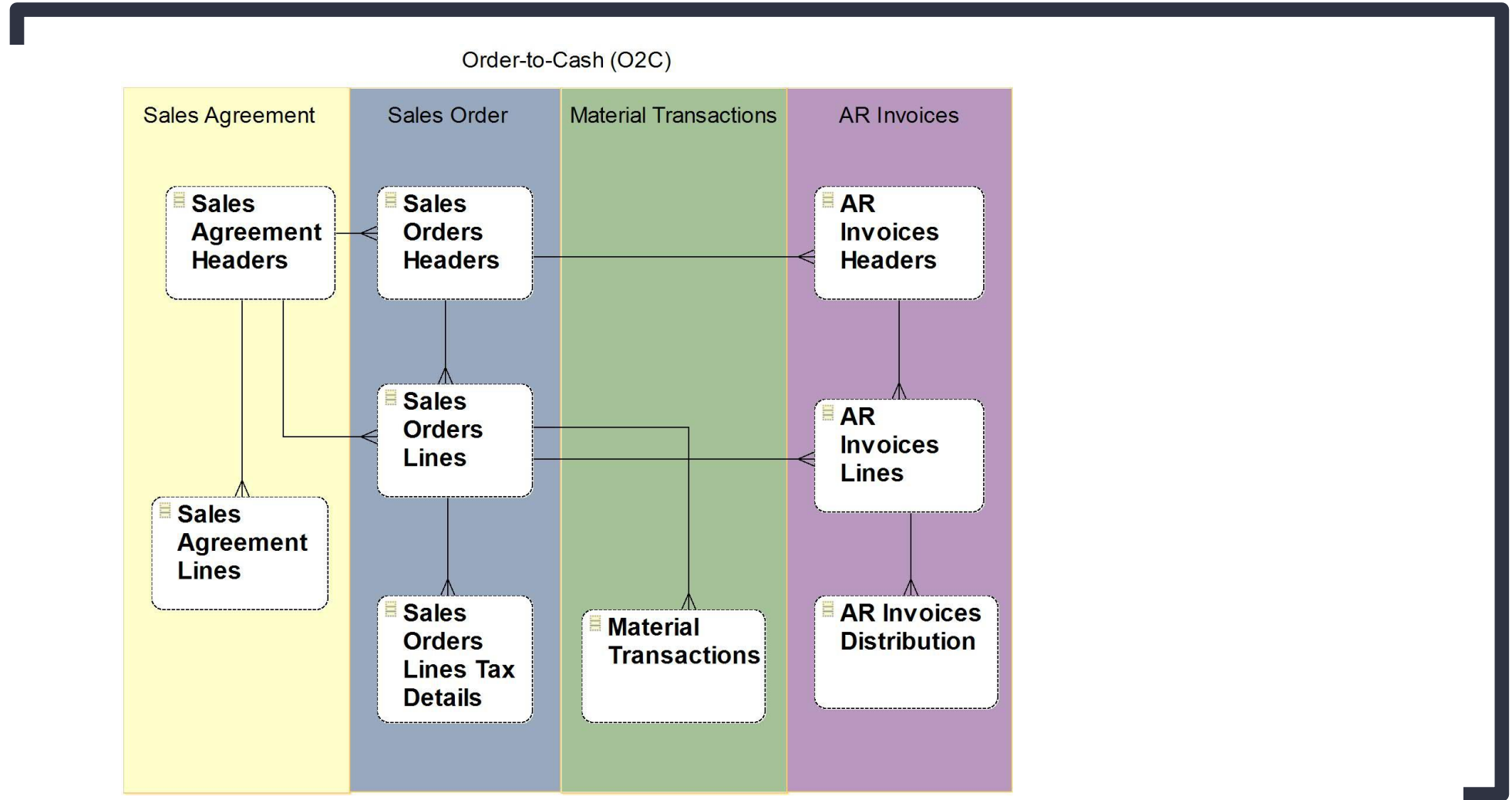

# SIMPLIFIED PROMATIS DATA MODEL AR

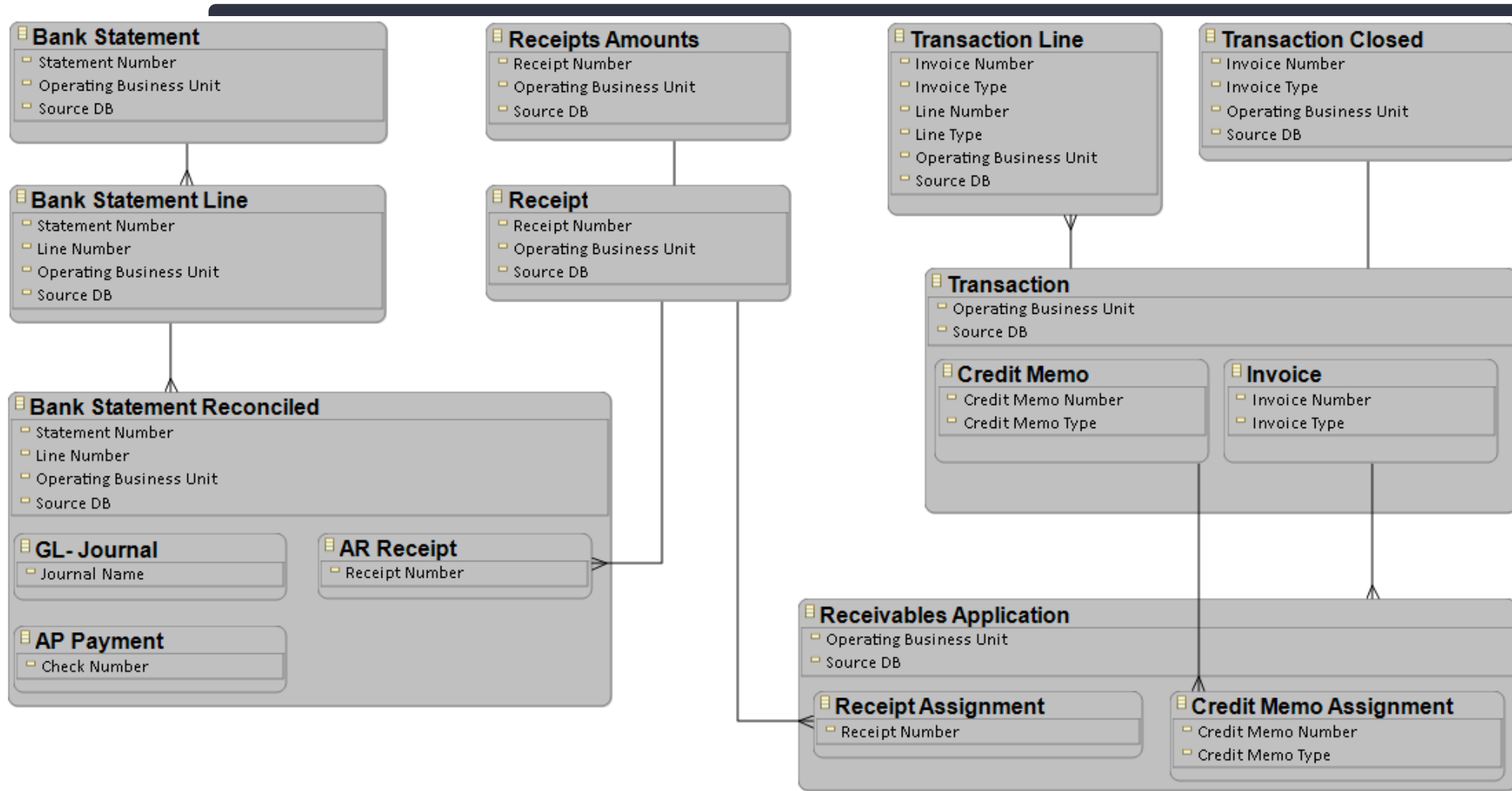

# PROMATIS DATASMART FOR HYBRID SYSTEMS

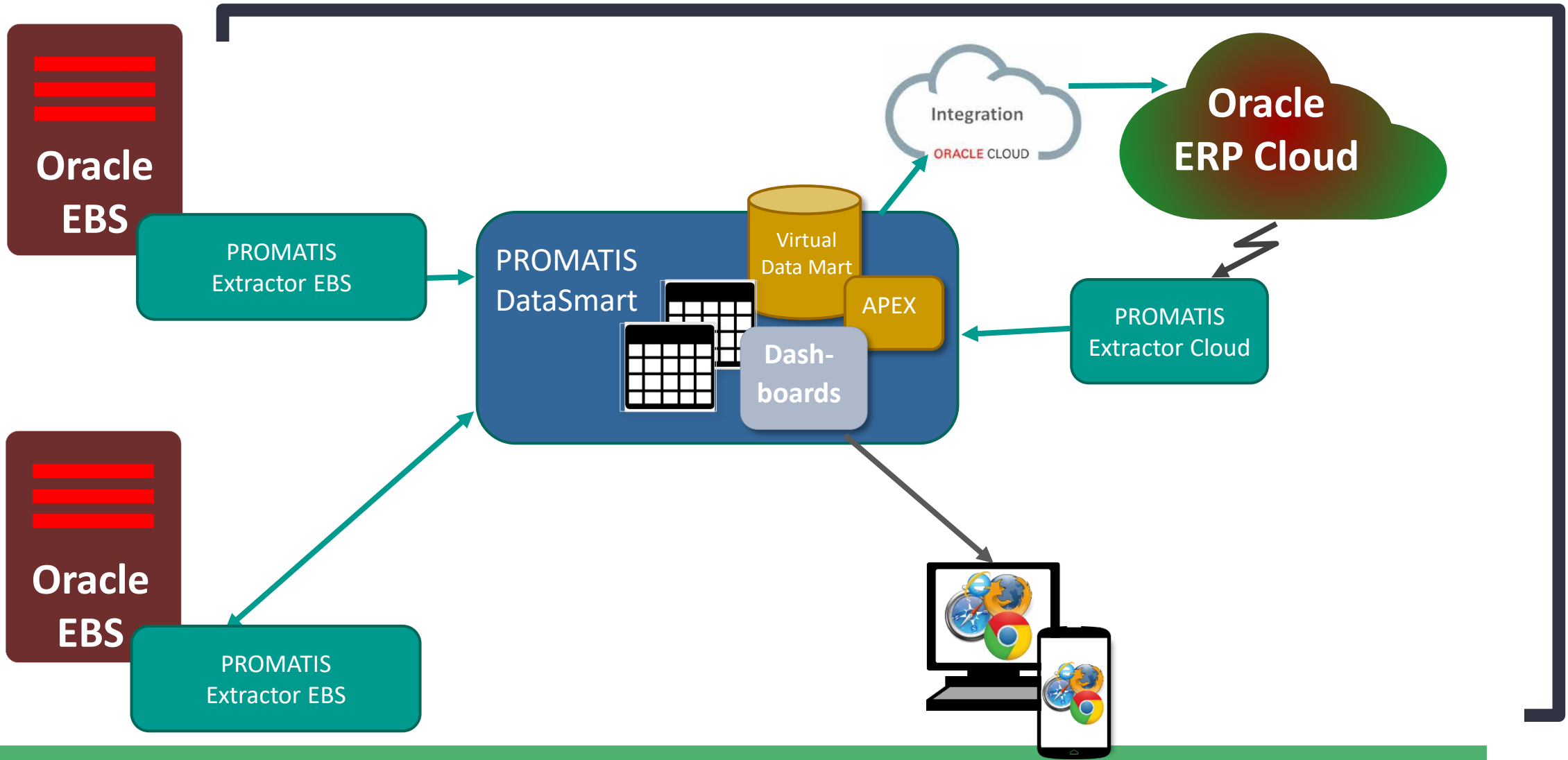



# AVAILABLE PLUGINS

A tailor-made standard solution for every requirement

- MDM: Extraction of complete master data records (customers, suppliers, items,...)
- MEC: Provision of tax-relevant data for tax authorities (transmission to IDEA)
- P2P: Extraction of supplier-relevant transactional data (requisitions, purchase orders,...)
- O2C: Extraction of customer-specific transactional data (sales orders, shipments, customer invoices)
- VAT-Extractor: Electronic transmission of VAT information

# Questions and Follow up

# SUMMARY DATASMART

- Incremental data upload available: Only new or modified records will be transferred into the DataSmart → Reduced transmission time.
- Data from several sources can be uploaded.
- An Oracle database is required to use DataSmart.
- Possibility to visualize and evaluate data (e.g. using APEX, Tableau, Qlikview,...).
- Common data model can be adjusted based on clients' requirements.

# CONTACT

## Michael Mohl

Dipl.-Wirtschaftsingenieur

Chief Financial Officer (CFO), PROMATIS Group

[michael.mohl@promatis.de](mailto:michael.mohl@promatis.de)